

QSS-FW100-03

Metal pipe Penetrating a flexible or rigid wall (100mm or thicker)



This standard detail is intended for general information only and all details should be checked against all relevant supporting test evidence, certification and installation guidelines. In line with the company's policy of continual development, details are subject to change and/ or withdrawal therefore you must ensure this is the latest published detail and instructions.

Additional Instructions

Flexible walls can be insulated or uninsulated and must have a minimum 50mm wide stud and minimum 2no. layers of 12.5mm Gypsum boards in accordance with EN 520 or Calcium Silicate boards which are CE Marked based on an ETA, on both sides of the stud.

Test results obtained with flexible supporting walls may be applied to concrete or masonry elements of an overall thickness equal to or greater than that of the element used in the test.

BS EN 1366-3:2021 Section 13.7: The distance between the aperture edges of penetration seals in a building element shall be as tested or minimum 100mm. The distance between the aperture edge of a penetration seal and any other penetration (e.g., door) in a building element shall be minimum 200mm.

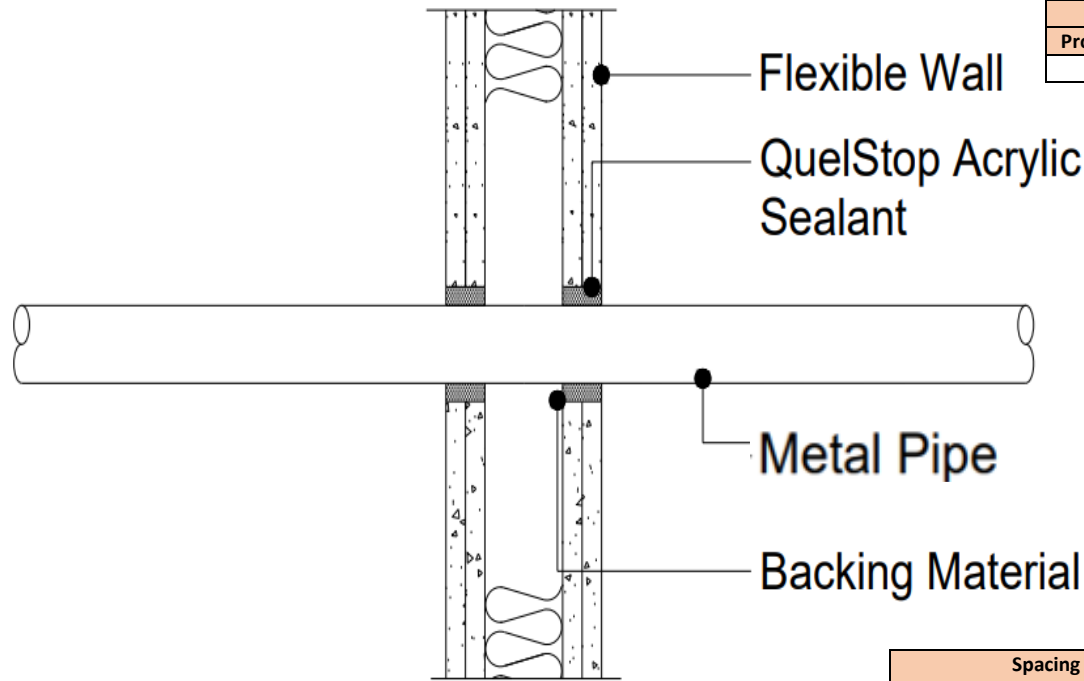

Quelfire Products Required	
Product Code	Description
QSS310	QuelStop Intumescent Acrylic Sealant

Spacing as per BS EN 1366-3: 2021, Section 13.7	
* Please also consider any requirements that the wall manufacturer has with regards to spacing between openings.	
Minimum distance from edge of opening to another aperture with a service penetration tested to BS EN 1366-3	100mm*
Minimum distance from edge of opening to another aperture with a penetration not tested to BS EN 1366-3	200mm*

Service Type	Size of services	Pipe Wall Thickness	Backing Material	QuelStop Acrylic Sealant (Installed both sides)	Classification
Cast Iron & Steel Pipe*	≤Ø42mm	2.8 - 14.2mm	PE Backing rod, glass wool, stone wool or ceramic wool	10mm Annulus	E 120 C/U EI 45 C/U
	Ø42 - 114mm	3.0 - 14.2mm		25mm Depth	E 120 C/U EI 20 C/U

* All metal pipe materials are covered which have a thermal conductivity equal or lower than the metal pipe tested and provided the melting point is at least equal or greater.

To be read in conjunction with:	UL EU Certificate 01192-CPR, Page 37
Test standard:	BS EN1366-3 & EN13501-2:2016
Substrate minimum thickness:	100mm
First Service Support:	≤400mm
Drawing Scale:	Not to Scale
Issue Number:	4
Date of Issue:	July 2023
Detail Reference:	QSS-FW100-03

Important Information:

- The supporting construction must be installed in accordance with the manufacturer's guidelines and must be capable of achieving the required fire rating of the firestop.
- All Services should be adequately supported either side of the firestop to ensure that no load is transferred onto the firestop seal.

Scope and Liability:

- Any Information provided by or on behalf of Quelfire Limited is provided for general information only. It is not intended to amount to advice on which you should rely. You must obtain professional or specialist advice before taking, or refraining from, any recommendation or action.
- The summary is not exhaustive and does not consider all issues relevant to the enquiry. It is limited to the information and time available to us. We have not verified any information made available to us by you or any other source, nor have we carried out a physical inspection of any property. We make no representations, warranties or guarantees, whether expressed or implied, that any information is accurate, complete or up to date.
- We do not accept a duty of care to you or any other person in respect of the enquiry, nor do we accept any liability to you or any other person for any loss arising out of or in connection with the enquiry or any reply provided by us. Different limitations and exclusions of liability arising as a result of the supply of any products or services by us to you, and these will be set out in our terms and conditions of supply, a copy of which is available on request.
- Full terms and conditions of sale are available at <https://www.quelfire.co.uk/terms-conditions-of-sale/>